



Stereoscopic Zoom Microscopes

SMZ445

SMZ460

Stereoscopic zoom microscope designed for excellent cost performance

The SMZ445 and SMZ460 stereoscopic zoom microscopes combine ease-of-use with high optical performance. Both models feature a compact design with light weight, porro prism optics and ESD protection to prevent electrostatic damage to samples. The SMZ445 incorporates a 45 degree inclination angle; whereby, the SMZ460 incorporates a 60 degree inclination angle making it ideal for OEM applications.

DIMENSIONS SMZ445

Shown with a 10X eyepiece and Plain Stand

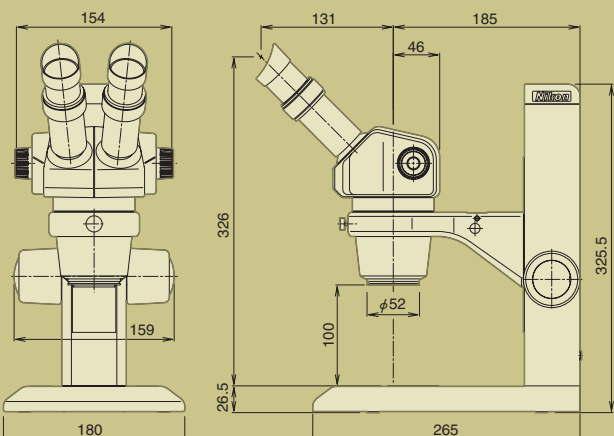

DIMENSIONS SMZ460

Shown with a 10X eyepiece and Focus Mount B

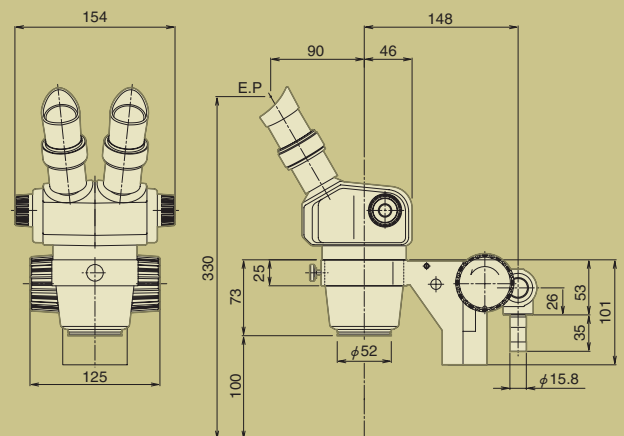

SPECIFICATIONS

	SMZ445	SMZ460
Type	Greenough zooming optical system with eyepiece correction mechanism on both eyepieces	
Total magnification	8x to 35x (4x to 70x by replacing eyepiece and/or auxiliary objective lens)	7x to 30x (3.5x to 60x by replacing eyepiece and/or auxiliary objective lens)
Eyepiece	SM 10xB eyepieces (F.N. 21), SM 15xB eyepieces (F.N.14), SM 20xB eyepieces (F.N. 12)	
Zoom range	0.8x to 3.5x (Zoom ratio: 4.4:1)	0.7x to 3x (Zoom ratio: 4.3:1)
Auxiliary objective lens	AL0.5x, 0.7x (optional)	
Working distance	100mm (standard configuration), 127.5mm (AL0.7x), 181mm (AL0.5x)	
Depression angle	45°	60°
Optical system	True erect image, 12° inner bevel, independent adjustment of right and left eyepieces, and 54 to 75mm interpupillary adjustment	
Weight (main unit only)	Approx. 1.0kg	

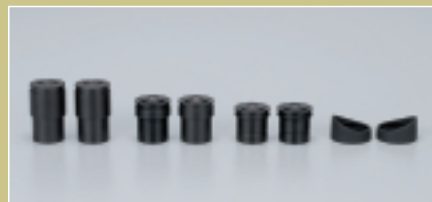

NEW - SMZ445/SMZ645 Eyepieces.
SM 10xB, SM 15xB, SM 20xB.
Eyecups available for SM 10xB eyepieces.

SYSTEM DIAGRAM

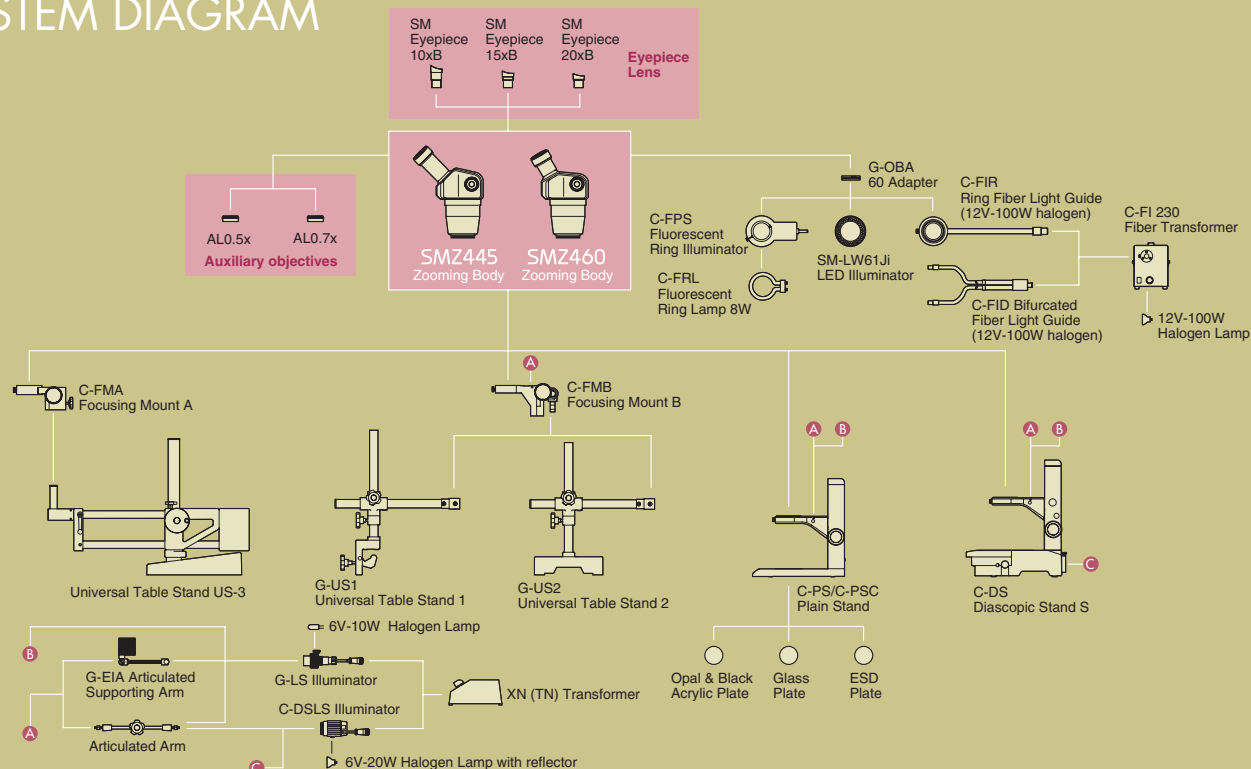

Specifications and equipment are subject to change without any notice or obligation on the part of the manufacturer. April 2007 ©2007 NIKON CORPORATION

The products detailed in the brochure are controlled by the Japanese Foreign Exchange and Foreign Trade Law and the International Export Control Regime. If there is a possibility that they may be utilized for the development of weapons of mass destruction, etc., they shall not be exported without authorization from the government.



WARNING

TO ENSURE CORRECT USAGE, READ THE CORRESPONDING MANUALS CAREFULLY BEFORE USING THE EQUIPMENT.



NIKON CORPORATION
Parale Mitsui Bldg., 8, Higashida-cho, Kawasaki-ku, Kawasaki,
Kanagawa 210-0005, Japan
phone: +81-44-223-2175 fax: +81-44-223-2182
<http://www.nikon-instruments.jp/eng/>



ISO 14001 Certified
NIKON INSTRUMENT CO., LTD.



ISO 9001 Certified
NIKON CORPORATION
Instruments Company



ISO 14001 Certified
NIKON CORPORATION
Yokohama Plant

NIKON INSTRUMENTS INC.

1300 Walt Whitman Road, Melville, N.Y. 11747-3064, U.S.A.
phone: +1-631-547-8500; +1-800-52-NIKON (within the U.S.A. only)
fax: +1-631-547-0306

<http://www.nikoninstruments.com/>

NIKON INSTRUMENTS EUROPE B.V.

P.O. Box 222, 1170 AE Badhoevedorp, The Netherlands
phone: +31-20-44-96-222 fax: +31-20-44-96-298

<http://www.nikon-instruments.com/>

NIKON INSTRUMENTS (SHANGHAI) CO., LTD.

CHINA phone: +86-21-5836-0050 fax: +86-21-5836-0030
(Beijing office) phone: +86-10-5869-2255 fax: +86-10-5869-2277
(Guangzhou office) phone: +86-20-3882-0552 fax: +86-20-3882-0580

NIKON SINGAPORE PTE LTD

SINGAPORE phone: +65-6559-3618 fax: +65-6559-3668

NIKON MALAYSIA SDN. BHD.

MALAYSIA phone: +60-3-78763887 fax: +60-3-78763387

NIKON INSTRUMENTS KOREA CO., LTD.

KOREA phone: +82-2-2186-8410 fax: +82-2-555-4415

NIKON CANADA INC.

CANADA phone: +1-905-625-9910 fax: +1-905-625-0103

NIKON FRANCE S.A.S.

FRANCE phone: +33-1-45-16-45-16 fax: +33-1-45-16-00-33

NIKON GMBH

GERMANY phone: +49-211-9414-0 fax: +49-211-9414-322

NIKON INSTRUMENTS S.p.A.

ITALY phone: +39-55-3009601 fax: +39-55-300993

NIKON AG

SWITZERLAND phone: +41-43-277-2860 fax: +41-43-277-2861

NIKON UK LTD.

UNITED KINGDOM phone: +44-20-8541-4440 fax: +44-20-8541-4584

NIKON GMBH AUSTRIA

AUSTRIA phone: +43-1-972-6111-00 fax: +43-1-972-6111-40

NIKON BELUX

BELGIUM phone: +32-2-705-56-65 fax: +32-2-726-66-45

