



Digital Cameras for Microscopy



DIGITAL CAMERA SYSTEM FOR MICROSCOPY

DIGITAL SIGHT SERIES



DS-Fi2



DS-Ri1



DS-Fi1c



DS-Vi1



DS-Qi1

A full lineup of camera heads suited to all microscopy samples.

Color and monochrome, cooled and non-cooled, 5.0-megapixel CCD and 2-megapixel CCD – a range of features in a choice of 5 models to suit every observation subject

NEW



High-definition color camera head

DS-Fi2

5.0 mega-pixels Color High-Resolution

The DS-Fi2 is capable of high-resolution 2560x1920 pixel shooting. In addition to a high-speed frame rate of 21 fps*, this model expands the range of settings available for exposure time to adapt to a wider variety of samples. Suitable for a wide range of applications including brightfield, phase contrast, and differential interference, the DS-Fi2 achieves high functionality and high cost-performance.

* When using DS-L3 and FAST mode



Ultra high-definition cooled color camera head

DS-Ri1

12.7 mega-pixels Color Cooled High-Resolution

Using new pixel shift technology, the DS-Ri1 achieves a high resolution of 12.7-megapixel output and 2200 TV lines. Its superior color reproduction allows faithful recording of sample colors, while a smooth video display makes focusing easy. Through -10°C ambient temperature cooling, clear color image acquisition of fluorescent specimens is possible.

* When DS-L3 is used standalone, combinations of recorded image format and pixel number are limited. Control via PC is recommended.



High-sensitivity cooled monochrome camera head

DS-Qi1

1.5 mega-pixels Cooled

The DS-Qi1 uses a cooled 1.5-megapixel CCD and drive circuits that achieve high quantitative capability with linearity of 2% or less, as well as high sensitivity and low noise. Accurately capturing minute changes in fluorescence, this model is ideal for applications such as time lapse-based quantitative analysis.

* See the DS-Qi1 catalog for details.
* When DS-L3 is used standalone, combinations of recorded image format and pixel number are limited. Control via PC is recommended.



High-speed color camera head

DS-Vi1

2.0 mega-pixels Color

The DS-Vi1 is equipped with a 2.0-megapixel color CCD that displays SXGA video at a high frame rate of 15 fps* (maximum 29 fps). This model is suitable for monitoring applications as well, with an excellent balance of smooth movement and clear imaging made possible through its high sensitivity.

* When using DS-L3 or external monitor output.



High-definition cooled color camera head

DS-Fi1c

5.0 mega-pixels Color Cooled High-Resolution

The DS-Fi1c is equipped with a 5.0-megapixel color CCD and Peltier element capable of cooling to a -20°C ambient temperature. Even in fluorescent image shooting requiring long exposure times, high-contrast images can be obtained with limited thermal background noise.

CCD	2/3" color, 5.0 megapixels	2/3" color, 1.5 megapixels	2/3" monochrome, 1.5 megapixels	1/1.8" color, 2.0 megapixels	2/3" color, 5.0 megapixels
Max recordable pixels	2560 x 1920	4076 x 3116 (Pixel shift mode) 1280 x 1024	1280 x 1024	1600 x 1200	2560 x 1920
Cooling device	-	10°C below ambient temperature (max.)	10°C below ambient temperature (max.)	-	20°C below ambient temperature
Display speed	U3 4.4 fps (2560 x 1920), max. 37 fps [Standalone] L3 10 fps (2560 x 1920), max. 37 fps [Used with NIS-Elements] 2.0 fps (2560 x 1920), max. 37 fps	U3 19 fps (1280 x 1024), max. 32 fps [Used with NIS-Elements] L3 19 fps (1280 x 1024), max. 32 fps	U3 19 fps (1280 x 1024), max. 48 fps [Standalone] L3 19 fps (1280 x 1024), max. 48 fps [Used with NIS-Elements] 19 fps (1280 x 1024), max. 32 fps	U3 12 fps (1600 x 1200), max. 27 fps [Standalone] L3 15 fps (1600 x 1200), max. 29 fps [Used with NIS-Elements] 5.0 fps (1600 x 1200), max. 27 fps	U3 4.4 fps (2560 x 1920), max. 23 fps [Standalone] L3 5.9 fps (2560 x 1920), max. 23 fps [Used with NIS-Elements] 2.0 fps (2560 x 1920), max. 23 fps
ISO sensitivity	Equivalent to ISO 64	Equivalent to ISO 200	Equivalent to ISO 800	Equivalent to ISO 100	Equivalent to ISO 64
Features and main applications	High resolution/brightfield, phase contrast, differential interference, etc.	High resolution, color reproduction, low noise, brightfield, multiple-staining color fluorescence, etc.	High sensitivity, low noise, quantitative capability, high frame rate/fluorescent time lapse, brightness analysis sensitivity	High-speed live display/brightfield, phase contrast, differential interference, etc.	High resolution, low noise/multiple-staining color fluorescence, etc.

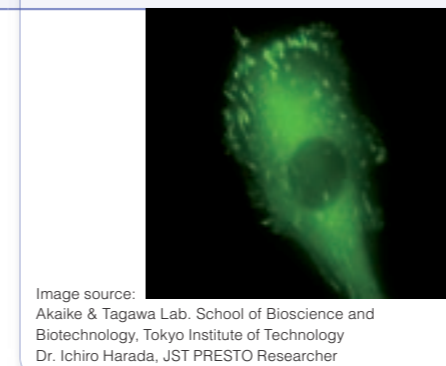
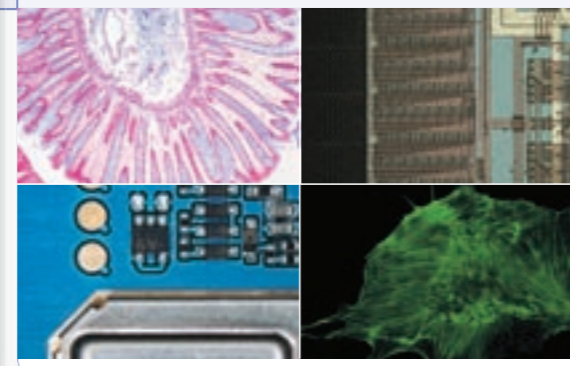
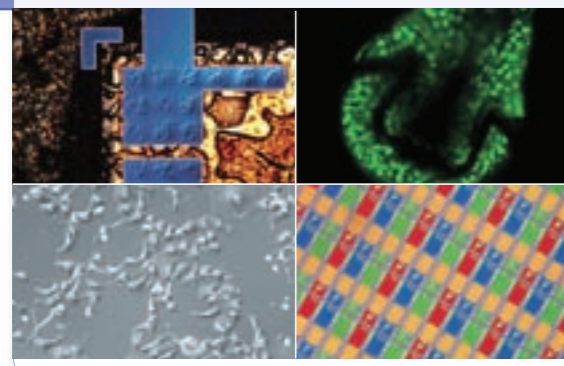
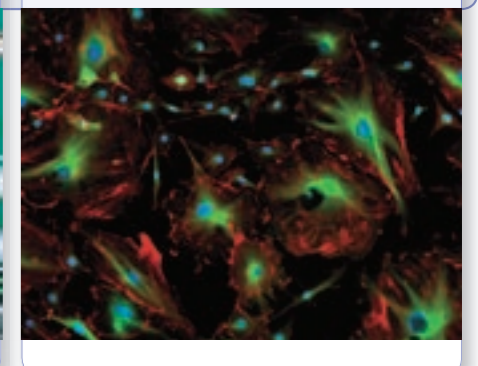
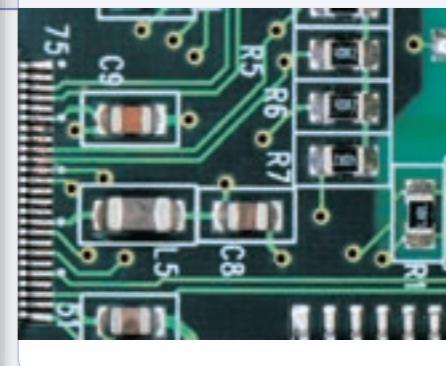

Image source:
Akaike & Tagawa Lab. School of Bioscience and Biotechnology, Tokyo Institute of Technology
Dr. Ichiro Harada, JST PRESTO Researcher





PC control-based control unit DS-U3

From display and shooting of live images to advanced image processing and analysis, the DS-U3 allows the control of all functions from a PC and is flexibly adaptable to a wide range of applications.

Adaptable to a wide range of applications

Using NIS-Elements imaging software, you can perform image acquisition, processing, and analysis with integrated control of the camera and microscope peripherals.

Integration with microscopes

The DS-U3 enables the control of a motorized microscope system (turning of nosepiece or filter turret, etc.) and automatic detection of objective magnification using a state detection nosepiece.



NIS-Elements screen

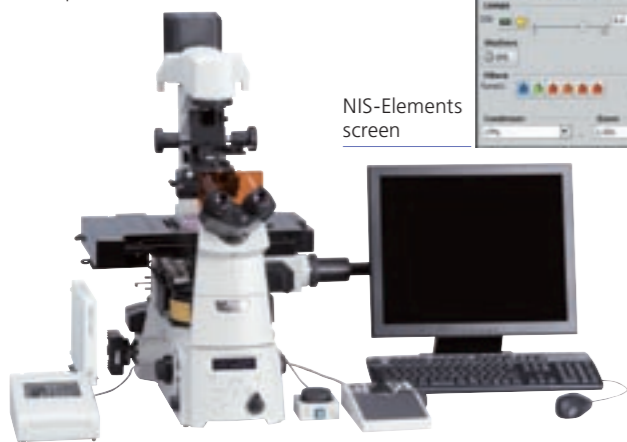

Configuration of ECLIPSE Ti



Configuration of ECLIPSE LV100D

Integration with the NIS-Elements comprehensive imaging software series

F Free package

Bundled

The bundled free package offers functions for the display of scale on live images, full-screen display, and more. The simple operation screen makes shooting easy.

D Documentation package

The documentation package is equipped with measurement and report creation functions. It enables general microscopic image acquisition in fields from biomedical to industrial, and is expandable through optional added features such as EDF and databases.

Br Ar Research package

The research package enables the construction of advanced image acquisition systems, including multidimensional imaging (up to 4 dimensions for Br, 6 dimensions for Ar), through integration with systemized microscopes. Sets equipped with a rich range of image processing and analysis functions are available for every application.

Compatible OS

DS-U3 Windows® 7 Pro 32/64bit

DS-L3 (Vendor unique) Windows® 7 Pro 32/64bit

* Nikon provides confirmed compatible PCs with up-to-date specifications. Contact Nikon for details.

Operation screen

Screen layout is selectable according to purpose. Using easy to understand buttons and tabs, the position of each window can be freely changed or its display turned on or off, providing a comfortable operating environment.

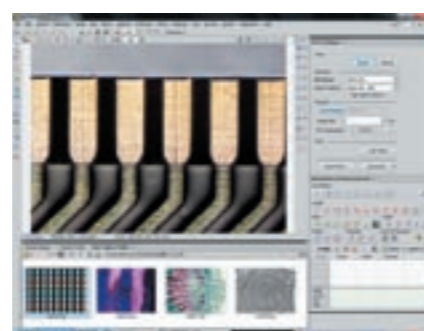

Docked Controls screen layout (NIS-Elements D)

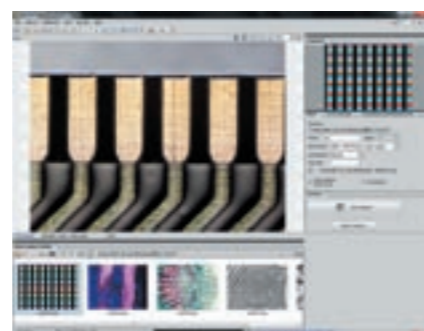

Simple Control screen layout (NIS-Elements D)

Nikon uses the NIS-Elements series as control software. NIS-Elements allows functions from basic imaging to control of the microscope and peripheral devices to be performed, as well as the measurement, analysis, and management of acquired images. Four basic packages and a variety of optional modules are available to suit every application and objective.

* See the NIS-Elements Catalog for details.



HDR (High Dynamic Range) image acquisition

HDR creates an image with appropriate brightness in both the dark and bright regions in a sample by combining multiple images acquired with different exposure settings. It is also possible to create HDR image using multiple captured images.

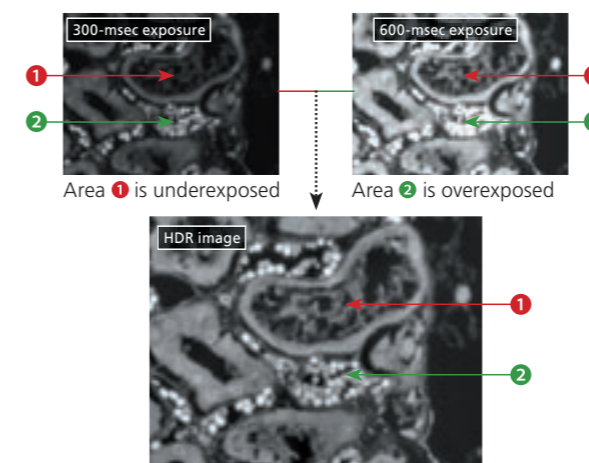

Captures both areas 1 and 2 with optimal exposure

EDF (Extended Depth of Focus)

Creates a single, all-in-focus image from images of differing focus. Viewing from various angles as a pseudo three-dimensional image is also possible.

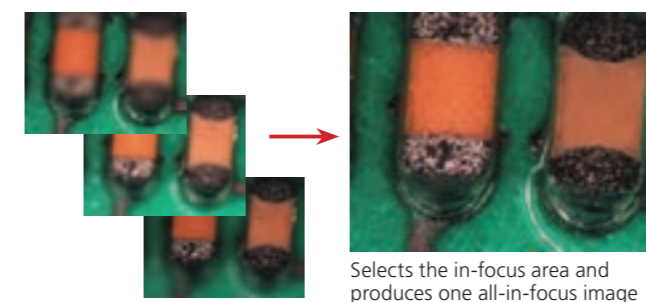

Selects the in-focus area and produces one all-in-focus image

Image stitching (Large Image)

Stitches together images from multiple fields of view during shooting to create an image with wide field of view. Images already acquired can also be stitched together.

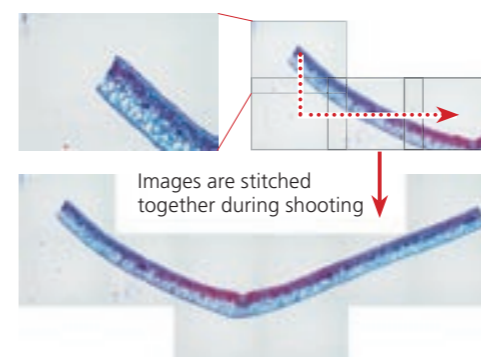

Images are stitched together during shooting

Manual measurement and image annotation

Manual Measurement allows easy measurement of length and area by drawing lines or an object directly on the image. The results can be attached to the image, and also exported as text or to an Excel spreadsheet.

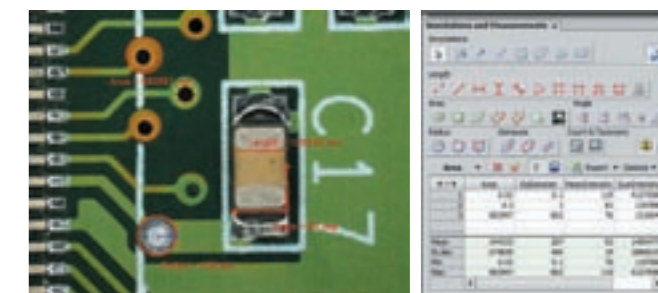

Auto measurement (Object Counting)

Performs binarization on images using previously set thresholds to measure the number, area, brightness, etc. of identified objects.

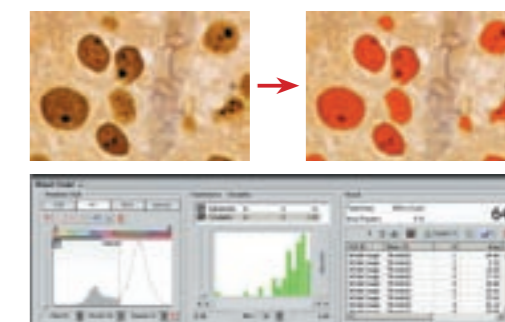

Grain size analysis

Detects and measures grains in one and two phase samples according to JIS G0551 or ASTM E112-96/E1382-97 standards.



Cast iron analysis

Detects, measures and classifies graphite content as well as ferrite content in graphite-corrected samples according to JIS G5502 or ASTM A247-06 standards.

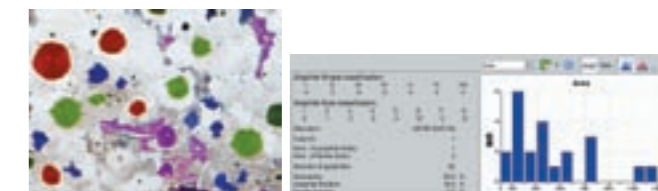

System Diagram

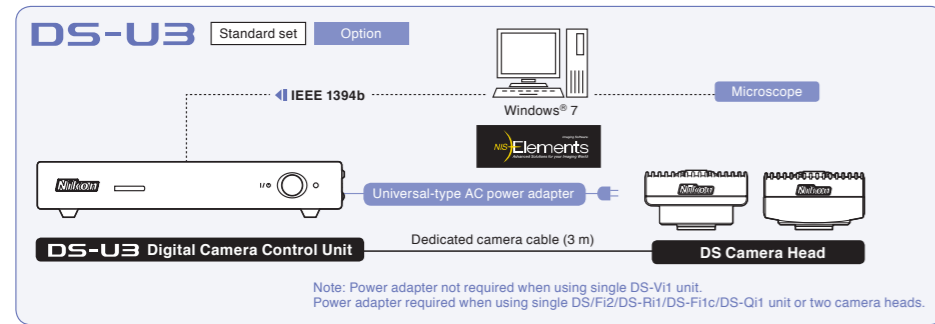
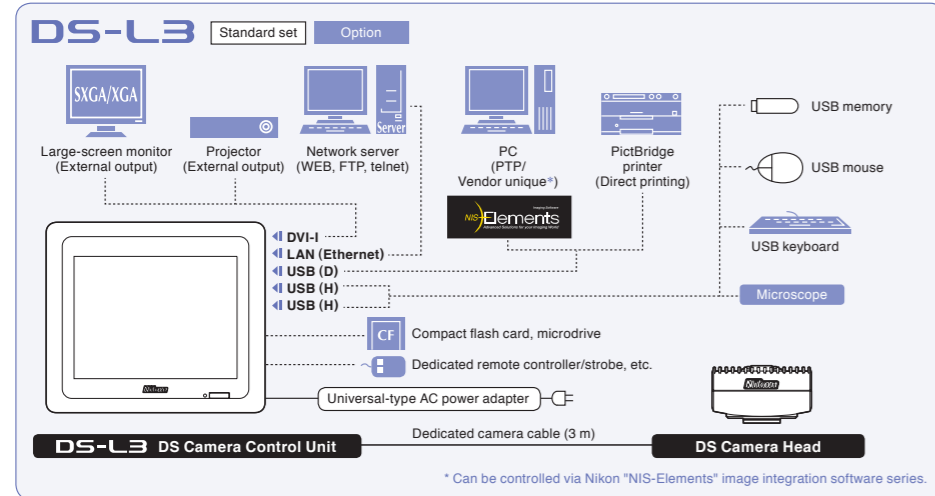

NIS-Elements Feature Chart

○ : Standard ● : Option

Main features for each package		F	D	Br	Ar
Image display	Enlarge/reduce, full screen, and magnifying glass	○	○	○	○
	Capture thumbnail	○	○	○	○
	Scale, annotation, and profile	○ (Live)	○	○	○
	Grid	○	○	○	○
	LUT, histogram	○	○	○	○
Image capture	3D surface view (EDF)	○	●	●	●
	Auto-capture	○	○	○	○
	Multidimensional image capturing	○	Up to 3D	Up to 4D	Up to 6D
	Time-lapse image capturing	○	Single	Variable	Variable
	Z-series image capturing, Multipoint image capturing	○	○	○	○
	Large image	○	○	○	○
	Live-stream compare	○	●	●	○
RAM capture	○	○	○	○	
Data formats	BMP, TIFF, JPEG, AVI, JPEG2000	○	○	○	○
	GIF, PNG, ICS/IDS, Nd2	○	○	○	○
	White balance	○	○	○	○
Image processing	LUT, shading correction	○	○	○	○
	Contrast, hue/saturation correction	○	○	○	○
	Edge enhancement, averaging, and smoothing	○	○	○	○
	EDF, real time EDF	○	●	●	○
	HDR (High Dynamic Range) image capture	○	●	●	○
	2D/3D deconvolution	○	○	○	●
Image editing	Crop	○	○	○	○
	Image overlay	3 (RGB)	4 (RGB+α)	Multichannel	Multichannel
	Cut, copy, paste, rotate, invert, and resize	○	○	○	○
	Component extraction	○	○	○	○
Image analysis	Pseudo-color	○	○	○	○
	Calibration (length)	○	○	○	○
	Manual measurement (count, length, area, angle, circle, and ellipse)	○	○	○	○
	Auto measurement (binarization, object count)	○	●	●	○
	3D measurement	○	●	●	●
Peripheral device control	Time measurement	○	○	○	○
	Microscope control	○	○	○	○
	Non-Nikon peripheral device control	○	●	●	●
Screen control	Organizer layout	○	○	○	○
	Layout manager	○	○	○	○
Other	Simple control mode	○	○	○	○
	Printing, PDF output, mail transmission	○	○	○	○
	Optical Configurations	○	○	○	○
	Report generator	○	○	○	○
	Macro	○	○	○	○
Database	○	●	●	●	

Dimensions

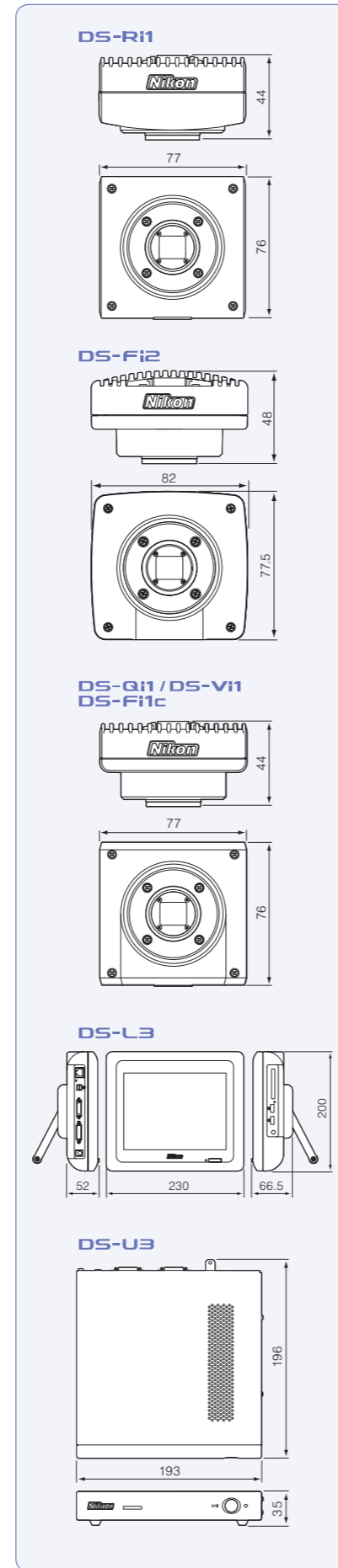

Specifications

Camera Head	DS-Ri1	DS-Fi2	DS-Fi1c
CCD	2/3 in. square pixel CCD; Total number of pixels: 1.5 megapixels (effective 1.45 megapixels)	2/3 in. high-density CCD; Total number of pixels: 5.24 megapixels (effective 5.07 megapixels)	
Recordable pixels	1280 x 1024, 640 x 512, 320 x 256 (4076 x 3116, 3840 x 3072, 1920 x 1536 (ROI mode) with DS-L3 vendor unique and DS-U3)	2560 x 1920, 1280 x 960, 640 x 480	
CCD cooling device	Peltier Device, 10°C below ambient temperature (max.)	—	Peltier Device, 20°C below ambient temperature (max.)
ISO Sensitivity (recommended exposure index)	Equivalent to ISO 200 (switchable sensitivity equivalent 100 to 2000)	Equivalent to ISO 64 (Can be varied between ISO 32-1250 equivalent)	
Live display mode (DS-L3 Standalone mode)	1280 x 1024 (max. 19 fps), 640 x 480 (max. 32 fps), ROI mode (max. 32 fps) *Display reduced or enlarged to SXGA/XGA	2560 x 1920 (max. 10 fps), 1280 x 960 (max. 21 fps), ROI mode (max. 37 fps) *Display reduced or enlarged to SXGA/XGA	2560 x 1920 (max. 5.9 fps), 1280 x 960 (max. 12 fps), ROI mode (max. 23 fps) *Display reduced or enlarged to SXGA/XGA
Live display mode (DS-L3/Used with NIS-Elements)	1280 x 1024 (max. 19 fps), 640 x 512 (max. 19 fps), 320 x 256 (max. 19 fps), ROI mode (max. 32 fps)	2560 x 1920 (max. 2.0 fps), 1280 x 960 (max. 7.8 fps), 640 x 480 (max. 21 fps), ROI mode (max. 37 fps)	2560 x 1920 (max. 2.0 fps), 1280 x 960 (max. 7.8 fps), 640 x 480 (max. 12 fps), ROI mode (max. 23 fps)
Live display mode (DS-U3)	1280 x 1024 (max. 19 fps), 640 x 512 (max. 19 fps), 320 x 256 (max. 19 fps), ROI mode (max. 32 fps)	2560 x 1920 (max. 4.4 fps), 1280 x 960 (max. 18 fps), 640 x 480 (max. 21 fps), ROI mode (max. 37 fps)	2560 x 1920 (max. 4.4 fps), 1280 x 960 (max. 12 fps), 640 x 480 (max. 12 fps), ROI mode (max. 23 fps)
Lens mount	C-mount		
Exposure time	1/1000 to 600 sec, 1/1000 to 60 sec (pixel-shifting mode)	130 μsec to 60 sec	1/1000 to 600 sec
Dimensions	77.0 (W) x 76.0 (D) x 44.0 (H) mm	82.0 (W) x 77.5 (D) x 48.0 (H) mm	77.0 (W) x 76.0 (D) x 44.0 (H) mm
Weight	Approx. 350 g	Approx. 270 g	Approx. 290 g

Camera Head	DS-Qi1	DS-Vi1
CCD	2/3 in. square pixel CCD; Total number of pixels: 1.5 megapixels (effective 1.45 megapixels)	1/1.8 in. high-density CCD; Total number of pixels: 2.11 megapixels (effective 2.01 megapixels)
Recordable pixels	1280 x 1024, 640 x 512, 640 x 480, 320 x 240	1600 x 1200, 800 x 600, 400 x 300
CCD cooling device	Peltier Device, 10°C below ambient temperature (max.)	
ISO Sensitivity (recommended exposure index)	Equivalent to ISO 800 (switchable sensitivity equivalent to ISO 400 to 8000)	
Live display mode (DS-L3 Standalone mode)	1280 x 1024 (max. 19 fps), 1280 x 720 (max. 24 fps), 640 x 480 (max. 32 fps), 320 x 240 (max. 48 fps), ROI mode (max. 32 fps) *Display reduced or enlarged to SXGA/XGA	1600 x 1200 (max. 15 fps), 800 x 600 (max. 27 fps), 800 x 560 (max. 29 fps), Center Scan (max. 29 fps) *Display reduced or enlarged to SXGA/XGA
Live display mode (DS-L3/Used with NIS-Elements)	1280 x 1024 (max. 19 fps), 640 x 512 (max. 19 fps), 640 x 480 (max. 32 fps), 320 x 240 (max. 48 fps), ROI mode (max. 32 fps)	1600 x 1200 (max. 5.0 fps), 800 x 600 (max. 27 fps), ROI mode (max. 15 fps)
Live display mode (DS-U3)	1280 x 1024 (max. 19 fps), 640 x 512 (max. 19 fps), 640 x 480 (max. 32 fps), 320 x 240 (max. 48 fps), ROI mode (max. 32 fps)	1600 x 1200 (max. 12 fps), 800 x 600 (max. 27 fps), ROI mode (max. 15 fps)
Lens mount	C-mount	
Exposure time	1/1000 to 600 sec	1/1000 to 60 sec
Dimensions	77.0 (W) x 76.0 (D) x 44.0 (H) mm	
Weight	Approx. 290 g	

Control Unit	DS-L3 (Standalone)	DS-L3 (Used with NIS-Elements)	DS-U3
Exposure control	Program AE, Shutter-priority AE, Focus AE, Manual with AE lock function	Auto / Manual	
Exposure correction	Correction range: ±2.0, Step: 1/3	13 steps	
Digital zoom	Up to 16x (8 steps)	10 to 1200%	
Interval shooting	10 sec. - 6 hr. intervals	—	
Exposure metering	Average metering, Peak hold metering		
Exposure metering range	Position/size adjustable		
White balance	Set method, Color balance adjustable		
Image adjustments	Gamma correction, shading adjustment, black level adjustment, Chroma, hue adjustment, color saturation adjustment		
Recordable image file format	RGB 8 bit (DS-Qi1: RGB 8 bit/monochrome 12 bit)	RGB 8 bit (DS-Qi1: monochrome 8 bit/12 bit), DS-Ri1: RGB 8 bit/16 bit)	RGB 8 bit/16 bit (DS-Qi1: monochrome 8 bit/12 bit)
Storage format	BMP, TIFF, JPEG (3-step compression)		BMP, TIFF, JPEG, JPEG2000 etc., selectable in NIS-Elements
Interface	USB device port x 1 (Printer, PTP support, Vendor unique / switching) USB host port x 2 (USB mouse, USB memory stick, USB keyboard, bar code reader, microscope connection), External sync input/output, Camera I/F x 1		IEEE1394b(bilingual) x 1 (computer control connection), External sync input/output, Camera I/F x 2
Power supply	AC100-240V 50/60Hz		
Power consumption	70 VA		36 VA
Dimensions	230 (W) x 66.5 (D) x 200 (H) mm		193 (W) x 196 (D) x 35 (H) mm
Weight	approx. 1800 g		approx. 1400 g
Operating environment	0-30°C, 80% RH max, 30-40°C, 60% RH max. (without condensation)		
Networking	Ethernet (10/100Base-TX), DHCP compatible, HTTP, TELNET or FTP server, FTP client		—
LCD monitor	8.4-in. TFT color LCD XGA (1024 x 768, 60Hz)		
External monitor output	DVI-I (Digital: Conforms to DVI 1.0/Analog: 0.7 Vpp (75 Ω) SXGA/XGA/720p)		
Storage media	USB memory stick, CompactFlash™ card		
Direct printing	PictBridge printer (sold separately)		